

40 HOURS CHALLENGE GROUND SCHOOL TO COCKPIT

A Complete Briefing on the DGCA Compliant Airline
Pilot Programme (June-December 2026 Batch).

Historic Fleet Expansions Demand Rapid Pilot Output

THE GLOBAL SHORTAGE

80,000+ pilots approaching mandatory retirement age. North American demand alone exceeds 128,000 pilots.

AIR INDIA MEGA-ORDER

470 new aircraft ordered from Boeing and Airbus (400 short-haul, 70 long-haul).

THE INDIGO RECORD

500 Airbus A320 family aircraft ordered in a record-breaking deal.

Indian airlines will need to hire over 10,000 pilots rapidly to keep pace with these historic fleet expansions. The bottleneck is no longer planes—it is qualified pilots.

Established Infrastructure Under Strict FAA Part 141 Regulation

01

THE LEGACY

Established in 1981. An iconic, pioneer pilot training institution located at John Wayne Airport in Southern California.

02

THE STANDARD

Approved by the Federal Aviation Administration (FAA) under Code of Federal Regulations Title 14 Part 141. Training is executed under a strictly enforced, globally recognised curriculum.

03

THE ENVIRONMENT

Train in California's unmatched aviation infrastructure. Fleet features Cessna 172 N, M, SP analog aircraft (glass cockpit G-1000s available by request).

The Four Mandatory Altitudes of Airline Preparation



ALT 1: PRIVATE PILOT (PPL)

Fundamentals.

Data: 36h Ground 128.8h Dual 17.5h Solo.

ALT 2: INSTRUMENT RATING (IR)

Flying in all weather.

Data: 24.5h Ground/Sim 135h Dual | 24.5h Solo.

ALT 3: COMMERCIAL PILOT (CPL)

Earning the right to fly for hire.

Data: 26.5h Ground/Sim | 55h Dual | 68h Solo.

ALT 4: MULTI-ENGINE (ME)

The final step for large airlines.

Data: 10h Ground/Sim 115h Dual.

Note: FAA Part 141 requires a minimum standard; OCFC strictly enforces syllabus hours to prevent unnecessary costs.

Strategies and Restrictions for the 1500-Hour Airline Goal

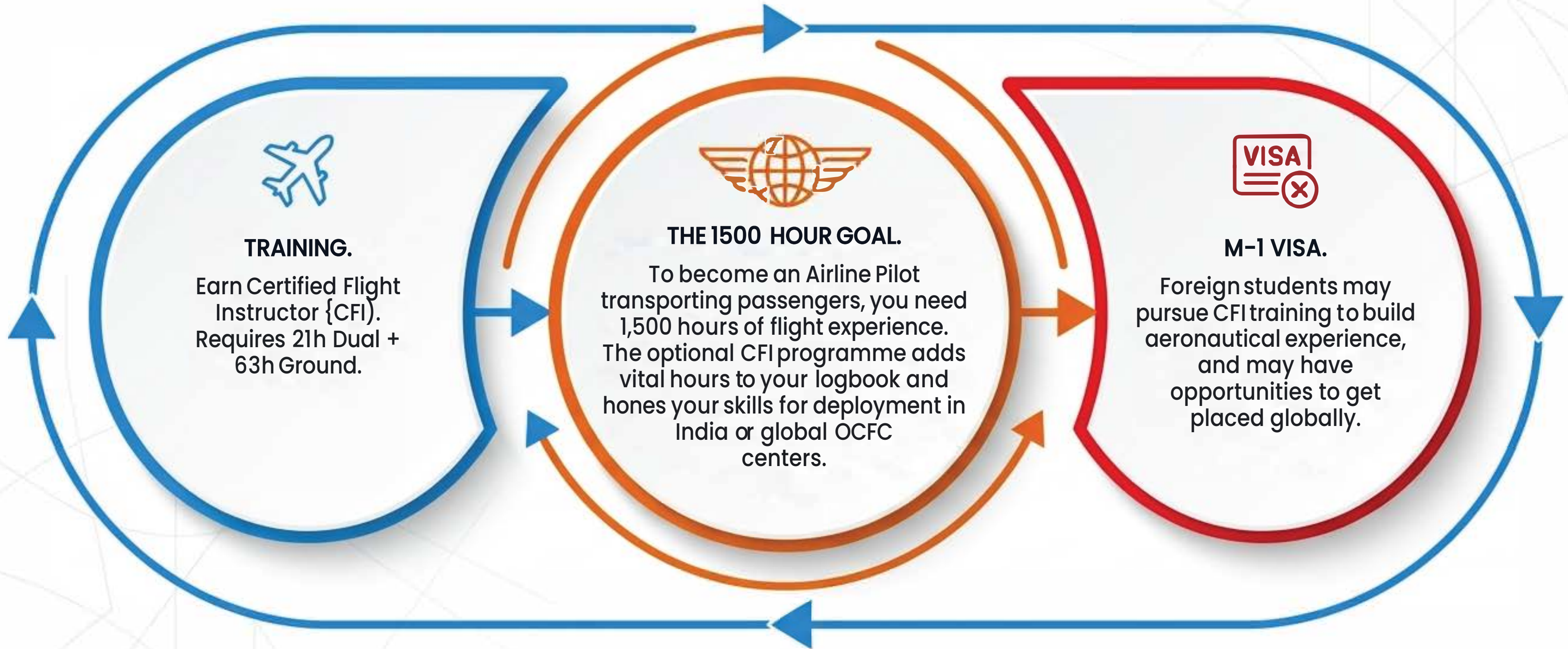

Transparent Allocation of Standard Programme Financials

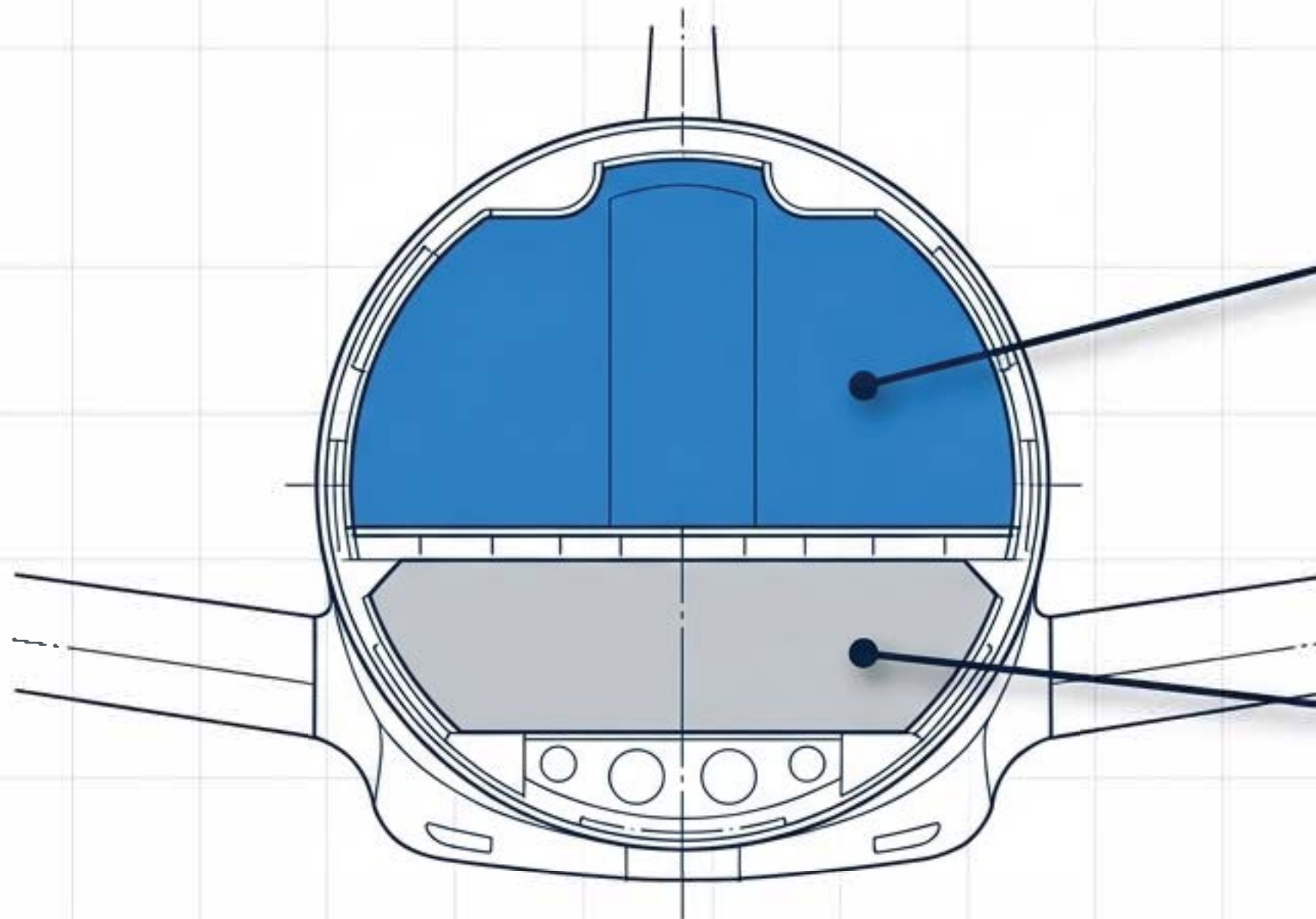

OCFC DIRECT TUITION

Standard Route Total: \$55,500.00 (w/o accommodation). With 8-Month Shared Accommodation: \$65,500.00. Includes: In-class Part 141 Ground School.

3RD PARTY REGULATORY COSTS

Designated Pilot Examiner (OPE) Check Rides: ~\$2,400.00.
Course Books/ King School Syllabus: \$1,200.00.
FAA Written Exams: \$165.00.
Medical (\$150), TSA (\$130), Fingerprinting (\$100).

Note: Pay-As-You-Go option available (\$2,500 down+ \$1,500 periodic payments).

The 40-Hour Private Pilot Challenge

STANDARD TRACK

Cost: \$55,500+

Pacing: National average to finish PPL is 60-75 hours.

Risk: Pay-as-you-go risk for extra hours.

THE CHALLENGE TRACK

Cost: **\$35,000.00 FLAT** (Down payment required upfront)

The Deal: If you finish your PPL in **40 hours**, OCFC **completely** sponsors your Instrument, Commercial, and Multi-Engine flight hours.







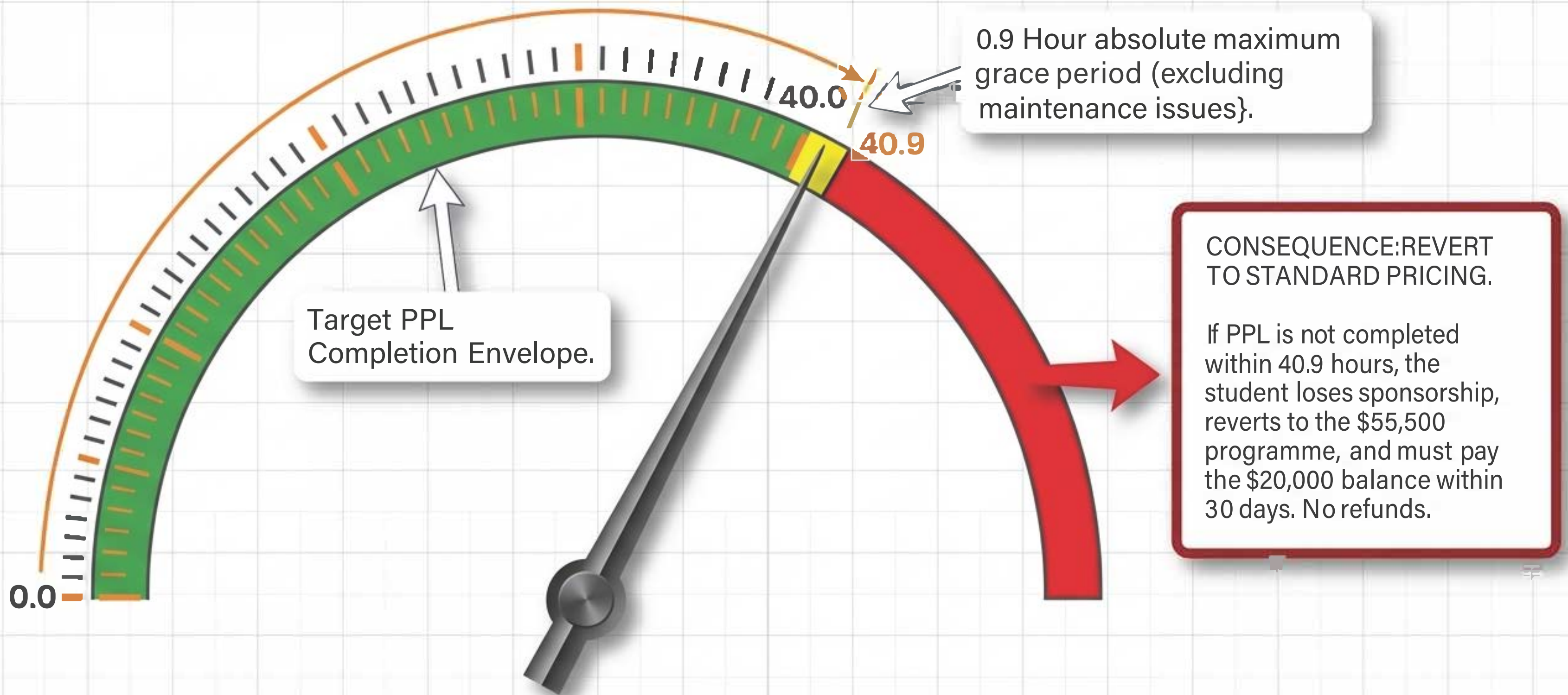

Bonus: Includes 3 months of **FREE** sponsored shared accommodation (saving an additional \$3,000).

THE BOTTOM LINE: A guaranteed savings of over £16,000 (\$20,500) for elite discipline

The Absolute 40.9 Hour Limit



Strict Parameters for Challenge Qualification

| GO (Mandatory Parameters) | | NO-GO | |
|---|--|---|---|
|  | 17+ years old with 3rd Class Medical & TSA Approval. |  | NO prior flight experience (even Demo/Discovery flights). |
|  | 100% attendance at LIVE OCFC ground school. |  | NO outside flight training concurrent with OCFC. |
|  | Fly at least once a week & complete homework promptly. |  | NO installment plans allowed for the \$35,000 down payment. |
|  | Pass the FAA check-ride on the first attempt. |  | Non Disclosure of flying experience in the past will lead to dis-qualification and forfeiture |
|  | Pass the Part 141 PPL written exam on the first attempt with 85%+ score. | | |

The Regulatory Bridge to India DGCA Compliance

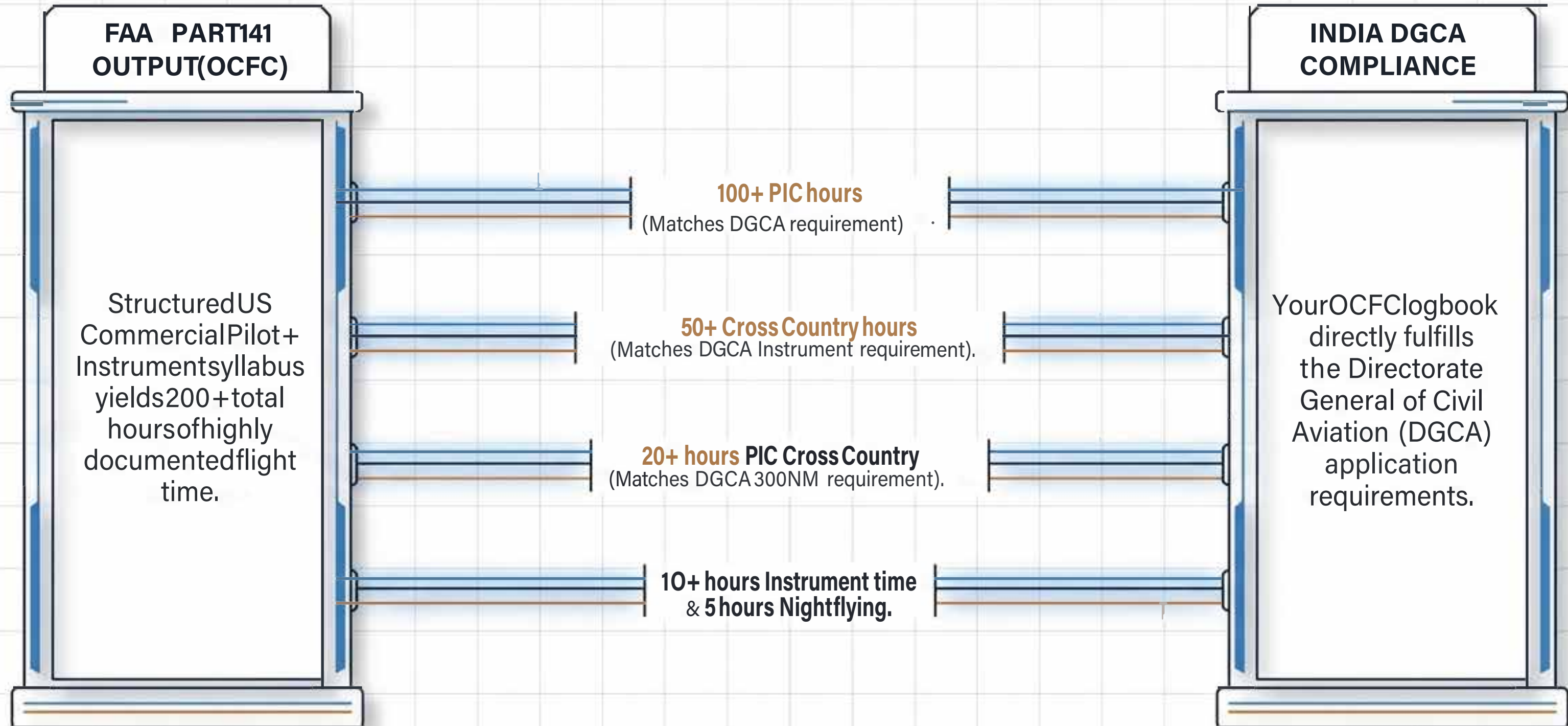

The Seven Steps from India to California



01 | Qualify:
17+, English proficiency, Passport, Proof of Funds.

02 | Apply:
Submit Admission App, docs, and bank statements/ Declaration.

03 | Interview:
Meet with DSO in-person in India or via WhatsApp; Receive 1-20.

04 | SEVIS:
Pay the online 1-901 fee matching your 1-20.

05 | Visa:
Schedule and pass your M-1 Student Visa Embassy interview.

06 | Fund & Schedule:
Pay tuition, secure housing, and confirm arrival date.

07 | Landing:
Arrive at LAX. OCFC concierge transports you to your furnished home.





Your Journey to the Airline Cockpit Begins Now

Enrollments open 365 days a year. Secure your seat in the June-December 2026 Batch and take the **40-Hour Challenge**.

Contact Dashboard

Director of Admissions: Niki-Alexander

Email: Niki-A@ocfc.com

Direct: (949) 756-1815 | Dispatch: (949) 756-1300

Campus: John Wayne Airport, 19531 Campus Drive, Santa Ana, CA 92707, USA.